

GATE VALVE QUICK CLOSING

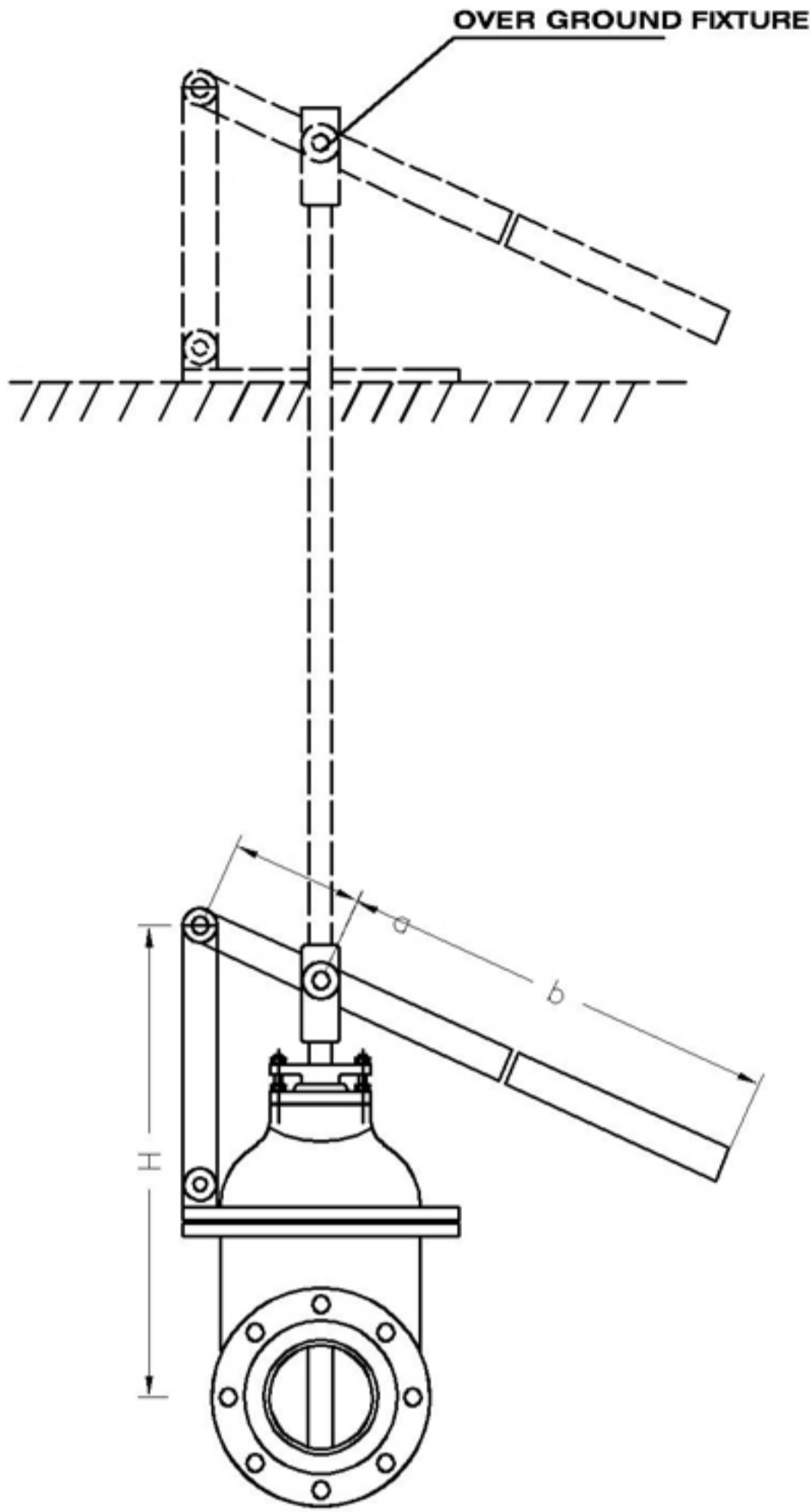

GATE VALVE QUICK CLOSING

FITTED WITH BALANCING COUNTER WIEGHT

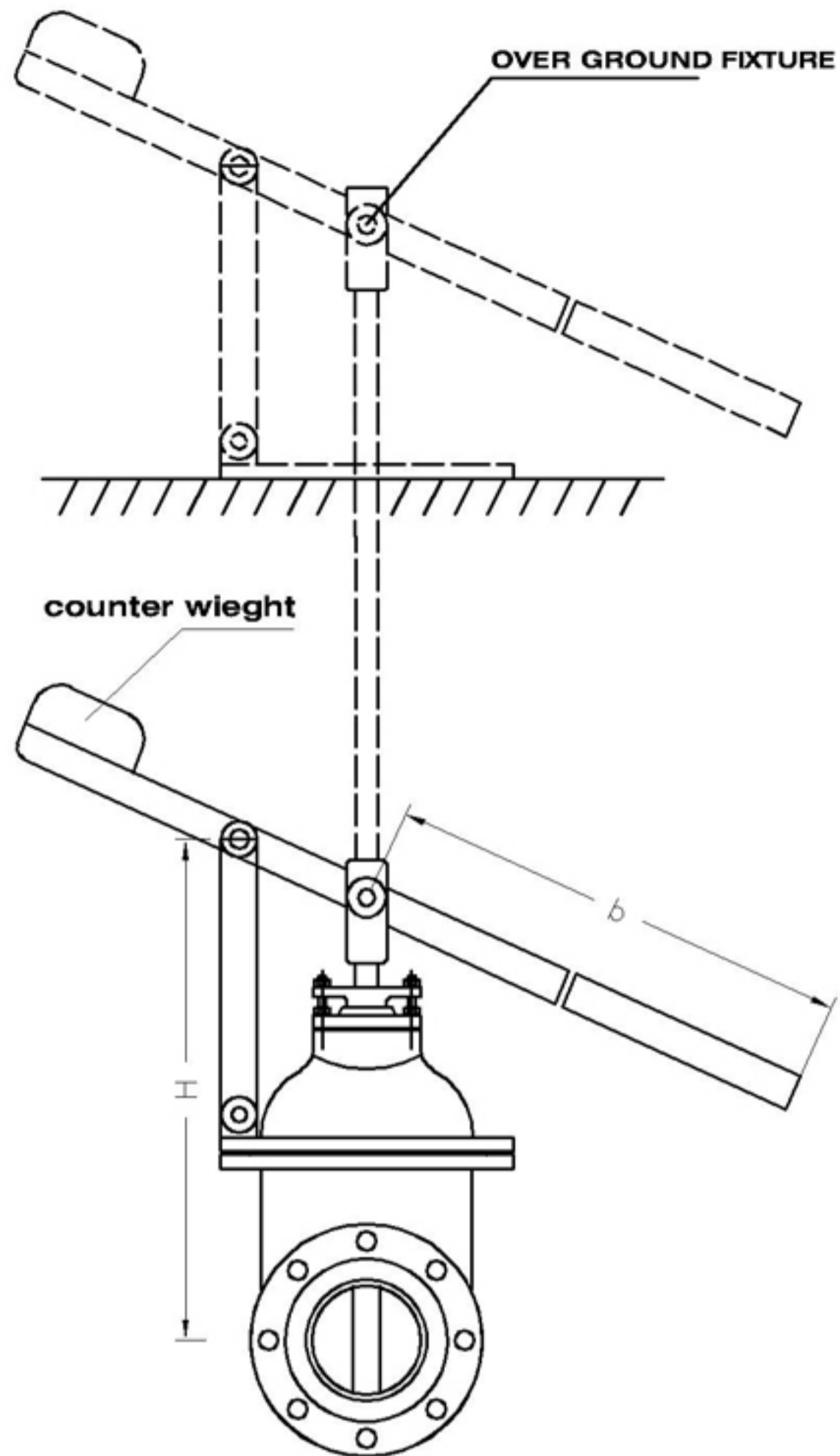

DN	H	a	b
80	385	110	445
100	430	120	465
150	570	160	560
200	675	205	720
250	795	245	850
300	905	280	900

DN	b	H
400	1500	1000
500	2000	1200
600	2000	1750

ALL DIM IN MM

DESCRIPTION :

QUICK OPENING OR QUICK CLOSING GATE VALVES ARE USED WHEN OPERATING TIME IS A CRITICAL FACTOR eg. emergency

SIZES 400MM AND 500 MM ARE FITTED WITH COUNTER WIEGHT to balance the weight of the gate

MATERIAL : G.C.I GG25/ D.C.I GGG50 ACCORDING TO ES. 1300 - ES 1 - ISO 1083

WORKING PRSSURE : 10/16 BAR

TESTING OF VALVES ACCORDING TO ISO 5208-1992 (E)

FLANGE CONNECTIONS ACCORDING TO ISO STANDARDS 2531

SUITABLE FOR WATER WORKS AND SEWAGE SYSTEMS



GATE VALVE RISING STEM



GATE VALVE NON RISING STEM



AIR VALVE



NON RETURN VALVE



SAFETY VALVE



VERTICAL FIRE HYDRANT

ENGINEERING INDUSTRIES

For Casting & Machining of Metals